

DISPOSABLE PRESSURE SENSITIVE
ADHESIVE FIXTURE HOLDS STUD
WHILE ADHESIVE CURES.

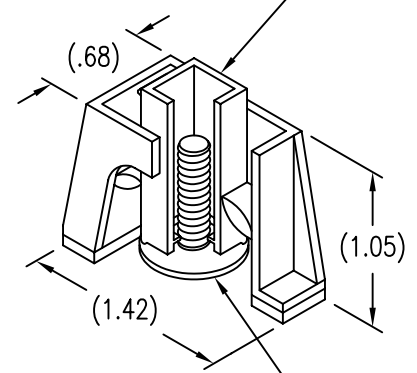

STUD ATTACHED BY ADHESIVE
APPLIED TO THIS SURFACE.

THREAD T DATA LENGTH L CODE (LENGTH L IN SIXTEENTHS OF AN INCH)

CODE	THREAD T	.250	.312	.375	.500	.625	.750	.875	1.000	1.250	1.500
440	.112-40 UNC-2A	4	5	6	8	10	12	14	16	-	-
632	.138-32 UNC-2A	4	5	6	8	10	12	14	16	20	24
832	.164-32 UNC-2A	4	5	6	8	10	12	14	16	20	24
1024	.190-24 UNC-2A	4	5	6	8	10	12	14	16	20	24
1032	.190-32 UNF-2A	4	5	6	8	10	12	14	16	20	24

BASEPLATE MATERIAL AND FINISH

CODE	BASEPLATE MATERIAL	FINISH
AX	ALUMINUM	NONE
AA	ALUMINUM	ANODIZE
CR	300 SERIES CRES	PASSIVATE
CRM	316 CRES	PASSIVATE

STUD MATERIAL AND FINISH

CODE	STUD MATERIAL	FINISH
AX	ALUMINUM	NONE
CR	300 SERIES CRES	PASSIVATE
S	CARBON STEEL	ZINC PLATE

OPTIONAL PRIMER

CODE	BASEPLATE PRIMER
P	EPOXY PRIMER

EXAMPLE PART NUMBER

CS62-1032-10 CR P

OPTIONAL PRIMER COATING ON BASEPLATE
STUD MATERIAL (IF DIFFERENT)
BASEPLATE MATERIAL - 300 SERIES CRES
STUD LENGTH L - .625
THREAD SIZE T - .190-32 UNF-2A
BASIC PART NUMBER

UNLESS OTHERWISE SPECIFIED, ALL DIMENSIONS ARE
IN INCHES AND TOLERANCES ARE AS SHOWN BELOW.
DIMENSIONAL TOLERANCES AND SYMBOLS PER ANSI
Y14.5M-1982.

PROPRIETARY PARTS SHOWN IN THIS DRAWING ARE THE SUBJECT
OF ISSUED UNITED STATES AND FOREIGN PATENTS AND PATENTS
PENDING.
UNAUTHORIZED REPRODUCTION AND/OR DISTRIBUTION OF THIS
DRAWING IS SPECIFICALLY PROHIBITED.

GLICK BOND

CARSON CITY
NEVADA 89706

CAD CS62-1

APPROVALS		DATE
DRAWN	DAC	17NOV00
CHECKED	DAC	17NOV00
RELEASED	CGH	17NOV00
REVISED	DAC	17NOV00

TITLE
STUD, SMALL BASE, ADHESIVE BONDED

SIZE	CAGE CODE	DWG. NO.	REV.
A	66530	CS62	9

SCALE 1/1 17NOV00 SHEET 1 OF 2

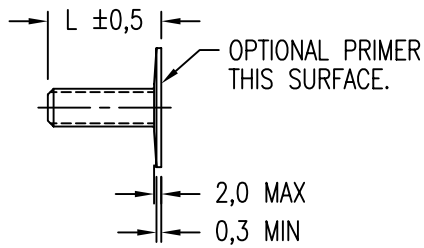
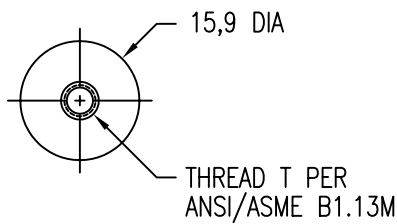

DISPOSABLE PRESSURE SENSITIVE ADHESIVE FIXTURE HOLDS STUD WHILE ADHESIVE CURES.

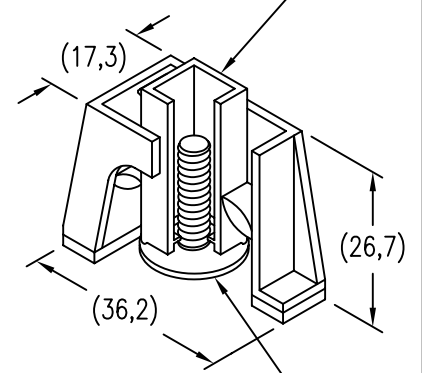

STUD ATTACHED BY ADHESIVE APPLIED TO THIS SURFACE.

THREAD T DATA LENGTH L CODE (LENGTH L IN MILLIMETERS)

CODE	THREAD T	6	8	10	12	15	18	20	25	30	35
3M	M3 X 0,5 6g	6M	8M	10M	12M	15M	18M	20M	25M	-	-
4M	M4 X 0,7 6g	6M	8M	10M	12M	15M	18M	20M	25M	30M	35M
5M	M5 X 0,8 6g	6M	8M	10M	12M	15M	18M	20M	25M	30M	35M
6M	M6 X 1,0 6g	-	-	10M	12M	15M	18M	20M	25M	30M	35M

BASEPLATE MATERIAL AND FINISH

CODE	BASEPLATE MATERIAL	FINISH
AX	ALUMINUM	NONE
AA	ALUMINUM	ANODIZE
CR	300 SERIES CRES	PASSIVATE
CRM	316 CRES	PASSIVATE

STUD MATERIAL AND FINISH

CODE	STUD MATERIAL	FINISH
AX	ALUMINUM	NONE
CR	300 SERIES CRES	PASSIVATE
S	CARBON STEEL	ZINC PLATE

OPTIONAL PRIMER

CODE	BASEPLATE PRIMER
P	EPOXY PRIMER

EXAMPLE PART NUMBER

CS62-5M 15M CR P

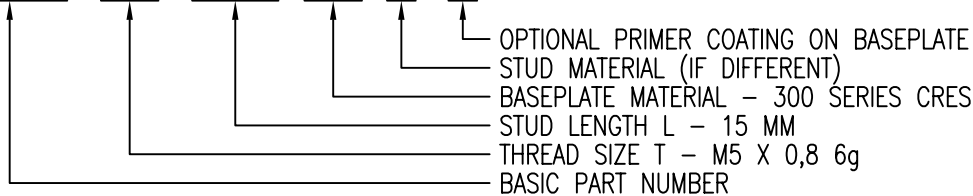

UNLESS OTHERWISE SPECIFIED, ALL DIMENSIONS ARE IN MILLIMETERS AND TOLERANCES ARE AS SHOWN BELOW. DIMENSIONAL TOLERANCES AND SYMBOLS PER ANSI Y14.5M-1982.

PROPRIETARY PARTS SHOWN IN THIS DRAWING ARE THE SUBJECT OF ISSUED UNITED STATES AND FOREIGN PATENTS AND PATENTS PENDING. UNAUTHORIZED REPRODUCTION AND/OR DISTRIBUTION OF THIS DRAWING IS SPECIFICALLY PROHIBITED.

GLICK BOND

CARSON CITY
NEVADA 89706

CAD CS62-1

METRIC DIMENSIONS

APPROVALS		DATE
DRAWN	DAC	17NOV00
CHECKED	DAC	17NOV00
RELEASED	CGH	17NOV00
REVISED	DAC	17NOV00

TITLE
STUD, SMALL BASE, ADHESIVE BONDED

ANGLES	±1°
.X	±0,8
.XX	±0,25

SIZE	CAGE CODE	DWG. NO.	REV.
A	66530	CS62 (METRIC)	9
SCALE	1/1	17NOV00	SHEET 2 OF 2