

NUTPLATE MEETS THE STRENGTH REQUIREMENTS OF NASM25027.

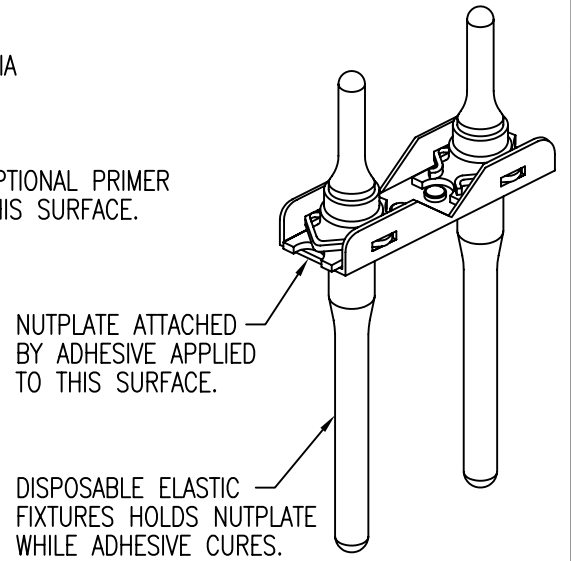

THREAD AND DIMENSION DATA (ALL DIMENSIONS BEFORE PAINT)

PART NUMBER	THREAD T	B MAX	D MIN	E MAX	H MAX	R MIN
CB6012CR08()1()	.1640-32 UNJC-3B	.454	.224	.187	.250	.070
CB6012CR3()1()	.1900-32 UNJF-3B	.454	.250	.187	.250	.070
CB6012CR3()2()					.312	.125
CB6012CR3()3()					.375	.188
CB6012CR3()4()					.437	.250
CB6012CR3()5()					.500	.313
CB6012CR3()6()					.562	.375
CB6012CR4()1()	.2500-28 UNJF-3B	.554	.312	.218	.295	.070
CB6012CR4()2()					.357	.125
CB6012CR4()3()					.419	.188
CB6012CR4()4()					.481	.250
CB6012CR4()5()					.543	.313
CB6012CR4()6()					.605	.375
CB6012CR5()1()	.3125-24 UNJF-3B	.650	.375	.276	.344	.070
CB6012CR5()2()					.400	.125
CB6012CR5()3()					.461	.188
CB6012CR5()4()					.524	.250
CB6012CR5()5()					.586	.313
CB6012CR5()6()					.649	.375

UNLESS OTHERWISE SPECIFIED, ALL DIMENSIONS ARE IN INCHES AND TOLERANCES ARE AS SHOWN BELOW. DIMENSIONAL TOLERANCES AND SYMBOLS PER ANSI Y14.5M-1982.

PROPRIETARY PARTS SHOWN IN THIS DRAWING ARE THE SUBJECT OF ISSUED UNITED STATES AND FOREIGN PATENTS AND PATENTS PENDING. UNAUTHORIZED REPRODUCTION AND/OR DISTRIBUTION OF THIS DRAWING IS SPECIFICALLY PROHIBITED.

GLICK BOND

CARSON CITY
NEVADA 89706

CAD CB6012-1

APPROVALS	DATE
DRAWN <i>DAC</i>	10FEB06
CHECKED <i>DAC/John</i>	10FEB06
RELEASED <i>CGH</i>	10FEB06
REVISED <i>DAC</i>	10FEB06

TITLE			
NUTPLATE, DOUBLE NUT, ADHESIVE BONDED			
SIZE	CAGE CODE	DWG. NO.	REV.
A	66530	CB6012	9
SCALE	2/1	10FEB06	SHEET 1 OF 4

NUT SPACING DIMENSION DATA

NUT SPACING CODE (IN EIGHTHS OF AN INCH)	P	A MAX FOR THD SIZES		
		08 AND 3	4	5
-5	.625	1.010	-	-
-6	.750	1.135	1.195	-
-7	.875	1.260	1.320	1.437
-8	1.000	1.385	1.445	1.562
-9	1.125	1.510	1.570	1.687
-10	1.250	1.635	1.695	1.812

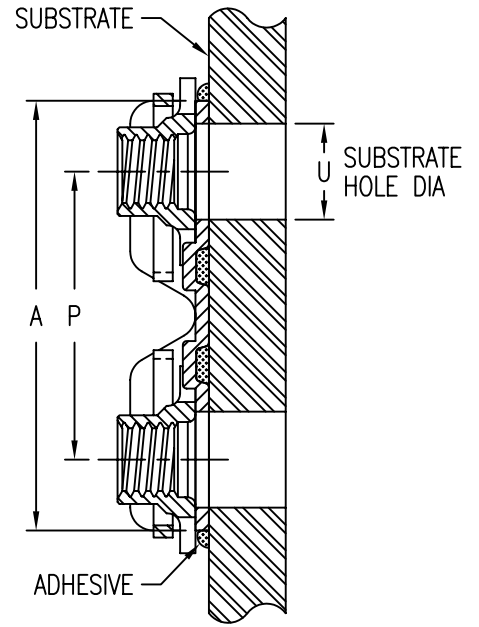

INSTALLATION HOLE SIZE DATA

THREAD CODE	U MIN	U MAX
08	.164	.224
3	.190	.250
4	.250	.312
5	.312	.375

BASEPLATE MATERIAL AND FINISH DATA

CODE	MATERIAL	SPEC.	PASSIVATE
CR	A-286 CRES	AMS 5525	AMS 2700

CLIP MATERIAL AND FINISH DATA (SEE CB6002)

CODE	MATERIAL	FINISH
CR	302, 18-2 MN, OR UNS S24100 CRES	PASSIVATE

NUT MATERIAL AND FINISH DATA (SEE CB6001)

CODE	MATERIAL	FINISH	LUBRICATION
-	A-286 CRES	PASSIVATE	DRI-FILM LUBE
CRC	A-286 CRES	CAD PLATE	DRI-FILM LUBE
CRS	A-286 CRES	SILVER PLATE	NONE

OPTIONAL BASEPLATE PRIMER

CODE	MATERIAL SPEC.
-	NONE
P	MIL-PRF-85582

NOTES: (NOTES 1 AND 2: PART NUMBER CHANGE 18NOV96, NUTPLATE DESIGN SAME. NOTES 3 AND 4: 10FEB06.)

- PART NUMBER CB6012CR2()1() IS INACTIVE FOR NEW DESIGN. USE PART NUMBER CB6012CR08()1() ().
- PART NUMBER CB6012CR()CR() () IS INACTIVE FOR NEW DESIGN. USE PART NUMBER CB6012CR()-() () ().
- CB6012A() () () () NUTPLATES ARE INACTIVE FOR DESIGN AND PROCUREMENT. USE CB6012CR() () () () ().
- CB6012AA() () () () () NUTPLATES ARE INACTIVE FOR DESIGN AND PROCUREMENT. USE CB6012CR() () () () ().

EXAMPLE PART NUMBER

CB6012 CR 3 - 1 P 6

"NL" SUFFIX TO PART NUMBER INDICATES NON-LOCKING NUT ELEMENT.

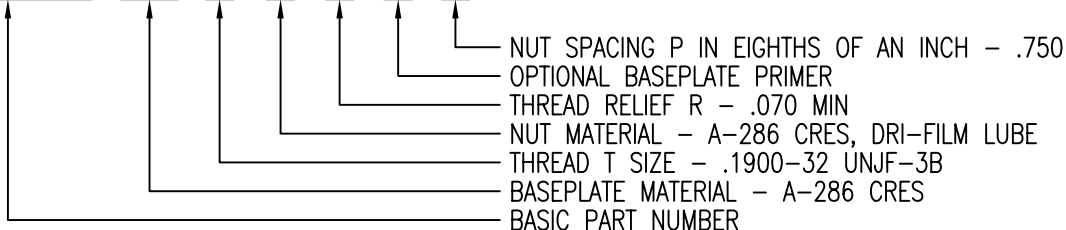

UNLESS OTHERWISE SPECIFIED, ALL DIMENSIONS ARE IN INCHES AND TOLERANCES ARE AS SHOWN BELOW. DIMENSIONAL TOLERANCES AND SYMBOLS PER ANSI Y14.5M-1982.

PROPRIETARY PARTS SHOWN IN THIS DRAWING ARE THE SUBJECT OF ISSUED UNITED STATES AND FOREIGN PATENTS AND PATENTS PENDING. UNAUTHORIZED REPRODUCTION AND/OR DISTRIBUTION OF THIS DRAWING IS SPECIFICALLY PROHIBITED.

GLICK BOND

CARSON CITY
NEVADA 89706

CAD CB6012-2		APPROVALS	DATE
ANGLES	±1°	DRAWN <i>DAC</i>	10FEB06
.XX	±.03	CHECKED <i>DAC/mtm</i>	10FEB06
.XXX	±.010	RELEASED <i>CGH</i>	10FEB06
.XXXX	±.001	REVISED <i>DAC</i>	10FEB06

TITLE			
NUTPLATE, DOUBLE NUT, ADHESIVE BONDED			
SIZE	CAGE CODE	DWG. NO.	REV.
A	66530	CB6012	9
SCALE	2/1		10FEB06
			SHEET 2 OF 4

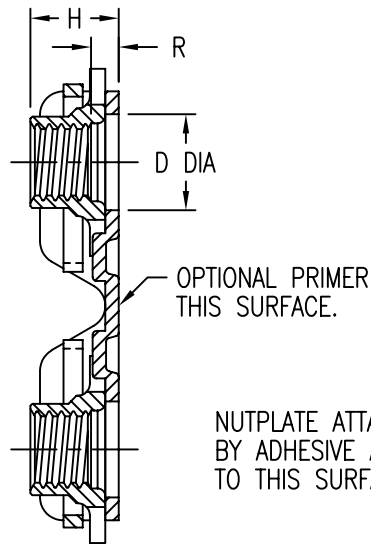
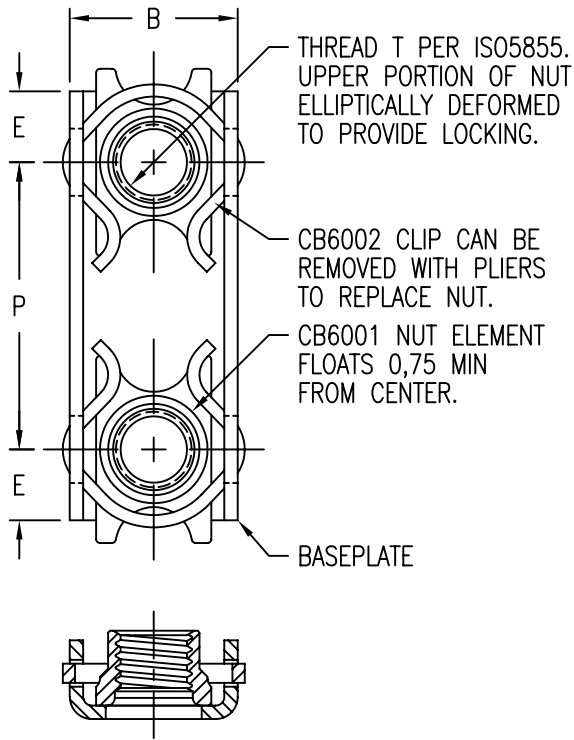

NUTPLATE MEETS THE STRENGTH REQUIREMENTS OF ISO5858.

NUTPLATE ATTACHED BY ADHESIVE APPLIED TO THIS SURFACE.

DISPOSABLE ELASTIC FIXTURES HOLDS NUTPLATE WHILE ADHESIVE CURES.

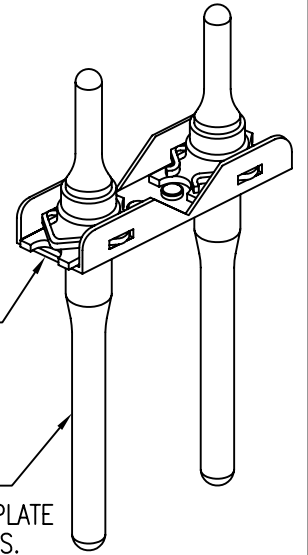

THREAD AND DIMENSION DATA (ALL DIMENSIONS BEFORE PAINT)

PART NUMBER	THREAD T	B MAX	D MIN	E MAX	H MAX	R MIN
CB6012CR4M()1() ()	MJ4 X 0,7 4H6H	11,6	5,50	4,8	5,2	1,6
CB6012CR5M()1() ()	MJ5 X 0,8 4H6H	11,6	6,35	4,8	6,2	1,6
CB6012CR5M()4() ()					8,0	4,0
CB6012CR5M()6() ()					10,0	6,0
CB6012CR5M()8() ()					12,0	8,0
CB6012CR5M()10() ()					14,0	10,0
CB6012CR6M()1() ()	MJ6 X 1,0 4H5H	14,1	7,50	5,6	7,1	1,6
CB6012CR6M()4() ()					9,0	4,0
CB6012CR6M()6() ()					11,0	6,0
CB6012CR6M()8() ()					13,0	8,0
CB6012CR6M()10() ()					15,0	10,0
CB6012CR8M()1() ()	MJ8 X 1,0 4H5H	16,6	9,50	7,1	8,2	1,6
CB6012CR8M()4() ()					11,0	4,0
CB6012CR8M()6() ()					13,0	6,0
CB6012CR8M()8() ()					15,0	8,0
CB6012CR8M()10() ()					17,0	10,0

UNLESS OTHERWISE SPECIFIED, ALL DIMENSIONS ARE IN MILLIMETERS AND TOLERANCES ARE AS SHOWN BELOW. DIMENSIONAL TOLERANCES AND SYMBOLS PER ANSI Y14.5M-1982.

PROPRIETARY PARTS SHOWN IN THIS DRAWING ARE THE SUBJECT OF ISSUED UNITED STATES AND FOREIGN PATENTS AND PATENTS PENDING. UNAUTHORIZED REPRODUCTION AND/OR DISTRIBUTION OF THIS DRAWING IS SPECIFICALLY PROHIBITED.

CLICK BOND

CARSON CITY
NEVADA 89706

CAD CB6012-3
METRIC DIMENSIONS

APPROVALS	DATE
DRAWN <i>DAC</i>	10FEB06
CHECKED <i>DAC/mtm</i>	10FEB06
RELEASED <i>CGH</i>	10FEB06
REVISED <i>DAC</i>	10FEB06

TITLE			
NUTPLATE, DOUBLE NUT, ADHESIVE BONDED			
SIZE	CAGE CODE	DWG. NO.	REV.
A	66530	CB6012 (METRIC)	9
SCALE	2/1	10FEB06	SHEET 3 OF 4

ANGLES	±1°
.X	±0,8
.XX	±0,25

NUT SPACING DATA

THREAD CODE	P MIN	P MAX
4M	16,0	32,0
5M	16,0	32,0
6M	19,0	32,0
8M	22,0	32,0

INSTALLATION HOLE SIZE DATA

THREAD CODE	U MIN	U MAX
4M	4,00	5,50
5M	5,00	6,35
6M	6,00	7,50
8M	8,00	9,50

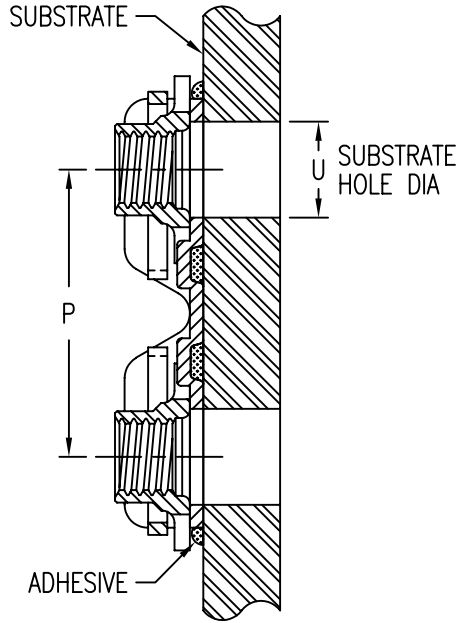

BASEPLATE MATERIAL AND FINISH DATA

CODE	MATERIAL	SPEC.	PASSIVATE
CR	A-286 CRES	AMS 5525	AMS 2700

CLIP MATERIAL AND FINISH DATA (SEE CB6002)

CODE	MATERIAL	FINISH
CR	302, 18-2 MN, OR UNS S24100 CRES	PASSIVATE

NUT MATERIAL AND FINISH DATA (SEE CB6001)

CODE	MATERIAL	FINISH	LUBRICATION
NONE	A-286 CRES	PASSIVATE	DRI-FILM LUBE
CRC	A-286 CRES	CAD PLATE	DRI-FILM LUBE
CRS	A-286 CRES	SILVER PLATE	NONE

OPTIONAL BASEPLATE PRIMER

CODE	MATERIAL SPEC.
-	NONE
P	MIL-PRF-85582

EXAMPLE PART NUMBER

CB6012 CR 5M 1 P 19

"NL" SUFFIX TO PART NUMBER INDICATES NON-LOCKING NUT ELEMENT.

- NUT SPACING P IN MILLIMETERS - 19,0
- OPTIONAL BASEPLATE PRIMER
- THREAD RELIEF R - 1,6 MIN
- NUT MATERIAL - A-286 CRES, DRI-FILM LUBE
- THREAD T SIZE - MJ5 X 0,8 4H6H
- BASEPLATE MATERIAL - A-286 CRES
- BASIC PART NUMBER

UNLESS OTHERWISE SPECIFIED, ALL DIMENSIONS ARE IN MILLIMETERS AND TOLERANCES ARE AS SHOWN BELOW. DIMENSIONAL TOLERANCES AND SYMBOLS PER ANSI Y14.5M-1982.

PROPRIETARY PARTS SHOWN IN THIS DRAWING ARE THE SUBJECT OF ISSUED UNITED STATES AND FOREIGN PATENTS AND PATENTS PENDING. UNAUTHORIZED REPRODUCTION AND/OR DISTRIBUTION OF THIS DRAWING IS SPECIFICALLY PROHIBITED.

GLICK BOND

CARSON CITY
NEVADA 89706

CAD CB6012-4
METRIC DIMENSIONS

APPROVALS	DATE
DRAWN <i>DAC</i>	10FEB06
CHECKED <i>DAC</i>	10FEB06
RELEASED <i>CGH</i>	10FEB06
REVISED <i>DAC</i>	10FEB06

TITLE
NUTPLATE, DOUBLE NUT, ADHESIVE BONDED

ANGLES	±1°
.X	±0,8
.XX	±0,25

SIZE	CAGE CODE	DWG. NO.	REV.
A	66530	CB6012 (METRIC)	9
SCALE	2/1	10FEB06	SHEET 4 OF 4