

MATERIAL AND FINISH DATA

CODE	NUT MATERIAL	SPEC.	RETAINER MATERIAL	SPEC.	FINISH	SPEC.
CR	A-286 CRES	AMS 5525	17-7PH, A-286, 304, 305 CRES	AMS 5528, 5525, 5514, 5639	PASSIVATE	QQ-P-35
CRA	A-286 CRES	AMS 5525	17-7PH, A-286, 304, 305 CRES	AMS 5528, 5525, 5514, 5639	PASSIVATE	QQ-P-35

THREAD T DATA AND DIMENSIONS

COUNTERBORE DATA - THD. RELIEF R AND NUT HEIGHT H

CODE	THREAD SIZE	A	B	C	D	CODE	NONE	2	3	4	5	6
08	.1640-32 UNJC-3B	.948	.525	.35	.250	R ±.025	.120	.165	.228	.291	.354	.417
3	.1900-32 UNJF-3B					H ±.025	.300	.362	.424	.486	.549	.612
4	.2500-28 UNJF-3B	1.292	.610	.45	.310	R ±.025	.150	.235	.298	.361	.424	.488
						H ±.025	.362	.424	.487	.549	.609	.672

MINIMUM NUT HEIGHT H LIMITED BY STRENGTH REQUIREMENTS ONLY.

CODE	BASEPLATE MATERIAL
C	CARBON/EPOXY, 350°F
G	GLASS/EPOXY, 250°F
E	GLASS/EPOXY, 350°F

EXAMPLE PART NUMBER

CB4009 G 3 CRA 2

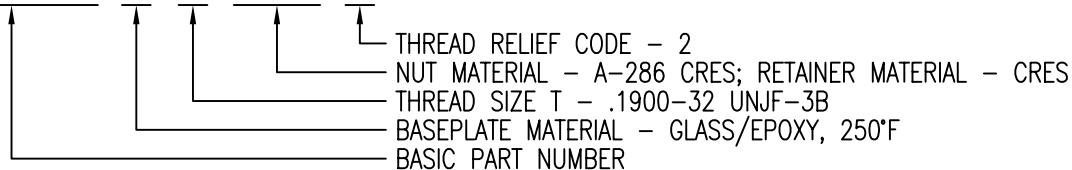

UNLESS OTHERWISE SPECIFIED, ALL DIMENSIONS ARE IN INCHES AND TOLERANCES ARE AS SHOWN BELOW. DIMENSIONAL TOLERANCES AND SYMBOLS PER ANSI Y14.5M-1982.

PROPRIETARY PARTS SHOWN IN THIS DRAWING ARE THE SUBJECT OF ISSUED UNITED STATES AND FOREIGN PATENTS AND PATENTS PENDING. UNAUTHORIZED REPRODUCTION AND/OR DISTRIBUTION OF THIS DRAWING IS SPECIFICALLY PROHIBITED.

GLICK BOND

CARSON CITY
NEVADA 89706

CAD CB4009-1		APPROVALS		DATE	TITLE			
ANGLES	±1°	DRAWN	BSP	27JUN01	NUTPLATE, TWO LUG, COMPOSITE BASE			
.XX	±.03	CHECKED	DAC	27JUN01	SIZE	CAGE CODE	DWG. NO.	REV.
.XXX	±.010	RELEASED	CGH	5JUL01	A	66530	CB4009	11
.XXXX	±.001	REVISED	BSP	27JUN01	SCALE	2/1 27JUN01		SHEET 1 OF 2

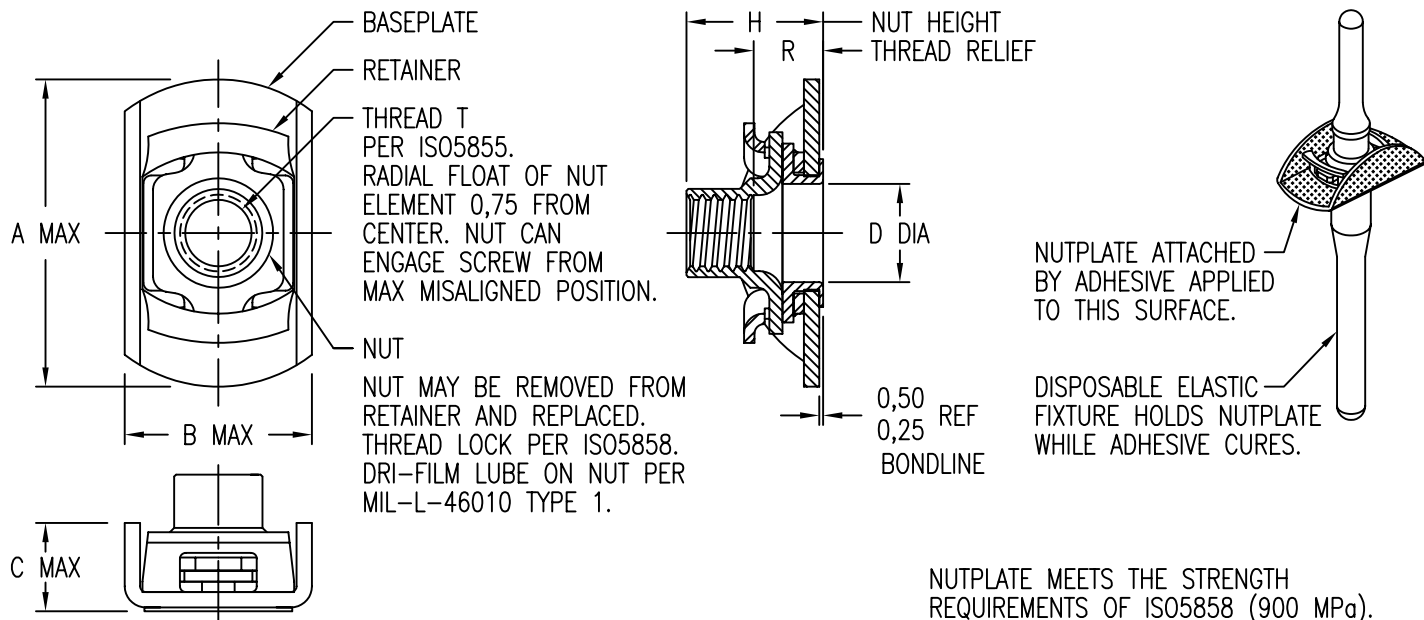

MATERIAL AND FINISH DATA

CODE	NUT MATERIAL	SPEC.	RETAINER MATERIAL	SPEC.	FINISH	SPEC.
CR	A-286 CRES	AMS 5525	17-7PH, A-286, 304, 305 CRES	AMS 5528, 5525, 5514, 5639	PASSIVATE	QQ-P-35
CRA	A-286 CRES	AMS 5525	17-7PH, A-286, 304, 305 CRES	AMS 5528, 5525, 5514, 5639	PASSIVATE	QQ-P-35

THREAD T DATA AND DIMENSIONS

COUNTERBORE DATA - THD. RELIEF R AND NUT HEIGHT H

CODE	THREAD SIZE	A	B	C	D	CODE	NONE	2	3	4	5	6
4M	MJ4 X 0,7 4H6H	24,1	13,4	8,9	6,35	R ±0,65	3,05	4,19	5,79	7,39	8,99	10,59
5M	MJ5 X 0,8 4H6H					H ±0,65	7,62	9,19	10,77	12,34	13,94	15,54
6M	MJ6 X 1,0 4H5H	32,9	15,5	11,5	7,87	R ±0,65	3,81	5,97	7,57	9,17	10,77	12,40
						H ±0,65	9,19	10,77	12,37	13,94	15,47	17,07

MINIMUM NUT HEIGHT H LIMITED BY STRENGTH REQUIREMENTS ONLY.

CODE	BASEPLATE MATERIAL
C	CARBON/EPOXY, 177°C
G	GLASS/EPOXY, 121°C
E	GLASS/EPOXY, 177°C

EXAMPLE PART NUMBER

CB4009 G 5M CRA 2

↑ ↑ ↑ ↑ ↑
 BASIC PART NUMBER BASEPLATE MATERIAL - GLASS/EPOXY, 121°C
 THREAD SIZE T - MJ5 X 0,8 4H6H
 NUT MATERIAL - A-286 CRES; RETAINER MATERIAL - CRES
 THREAD RELIEF CODE - 2

UNLESS OTHERWISE SPECIFIED, ALL DIMENSIONS ARE IN MILLIMETERS AND TOLERANCES ARE AS SHOWN BELOW. DIMENSIONAL TOLERANCES AND SYMBOLS PER ANSI Y14.5M-1982.

PROPRIETARY PARTS SHOWN IN THIS DRAWING ARE THE SUBJECT OF ISSUED UNITED STATES AND FOREIGN PATENTS AND PATENTS PENDING. UNAUTHORIZED REPRODUCTION AND/OR DISTRIBUTION OF THIS DRAWING IS SPECIFICALLY PROHIBITED.

GLICK BOND

CARSON CITY
NEVADA 89706

CAD CB4009-2 METRIC DIMENSIONS	
ANGLES	±1°
.X	±0,8
.XX	±0,25

APPROVALS	DATE
DRAWN BSP	27JUN01
CHECKED DAC	27JUN01
RELEASED CGH	5JUL01
REVISED BSP	27JUN01

TITLE NUTPLATE, TWO LUG, COMPOSITE BASE			
SIZE	CAGE CODE	DWG. NO.	REV.
A	66530	CB4009 (METRIC)	11
SCALE	2/1	27JUN01	SHEET 2 OF 2